

ARTICLE XXXIII (O)

OJUS URBAN AREA DISTRICT

Sec. 33-284.99.14 Purpose, intent and applicability.

- A. The regulations contained in this chapter and Chapter 18A, Landscape Code, Code of Miami-Dade County, Florida, shall apply to this article, except as otherwise added to or modified herein.
- B. The Illustrative Master Plan (Figure 1), illustrates the citizens' vision and may be used to interpret this article. Where the Illustrative Master Plan conflicts with the text of this article, the text shall govern.
- C. The regulations contained in this chapter address portions of the Ojus/Aventura Metropolitan Urban Center and its surrounding area. Specifically it addresses an area with the boundaries shown in the Boundary Plan, hereafter the Ojus Urban Area District (OUAD) and generally described as follows: from the crossing of the Oleta River with the west side of the Florida East Cost (FEC) railroad easement, then north along the west side of the FEC railroad easement to the south side of NE 203 Street, then west along the south side of NE 203 Street to the west side of NE 26 Avenue, then north along the west side of NE 26 Avenue to the south side of theoretical NE 206 Street then west along the south side of theoretical NE 206 Street to the eastern boundary of the Highland Oaks Park, then north and west along the boundary of Highland Oaks Park to the east side of NE 23 Avenue, then south on the east side of NE 23 Avenue to the north side of NE 207 Street, then east along the north side of NE 207 Street to the east side of NE 24 Avenue, then south along the east side of NE 24 Avenue to the south side on NE 203 Street, then east along the south side of NE 203 Street to the Oleta River, then south along the Oleta River to the point of beginning.

A more detailed legal description of the boundaries follows:

Beginning at the intersection of the East Right-of-Way line of the Oleta River with the West Right-of-Way line of the Florida East Coast railroad, thence North along the aforementioned West Right-of-Way line of the Florida East Coast railroad to the intersection with the centerline of NE 203 Street, thence West along the aforementioned centerline of NE 203 Street to the intersection with the

centerline of NE 26 Avenue, thence North along the aforementioned centerline of NE 26 Avenue to the intersection with the theoretical extension of the North Property line of Tract "A" of BETH TORAH ADATH YESHURUN as recorded in Plat Book 147, Page 50 of the Miami-Dade County Public Records, thence West along the aforementioned North Property line of Tract "A" to the intersection with the East Right-of-Way line of the Oleta River, thence North along the aforementioned East Right-of-Way line of the Oleta River to the intersection with the East Property line of Highland Oaks Park, thence North along the aforementioned East Property line of Highland Oaks Park to the intersection with the North Property line of Highland Oaks Park, thence West along the aforementioned North Property line of Highland Oaks Park to the theoretical intersection with the centerline of NE 23 Avenue, thence South along the aforementioned centerline of NE 23 Avenue to the intersection with the Northern boundary of Highland Oaks Elementary School, thence East along the aforementioned Northern boundary of Highland Oaks Elementary School for a distance of 546 feet (+/-) to a point, thence Southeast along the Northeast boundary of Highland Oaks Elementary School for a distance of 125 feet (+/-) to a point, thence East to the intersection with the centerline of NE 24 Avenue, thence South along the aforementioned centerline of NE 24 Avenue to the intersection with the centerline of NE 203 Street, thence East along the aforementioned centerline of NE 203 Street to the intersection with the East Right-of-Way line of the Oleta River, thence South along the aforementioned East Right-of-Way line of the Oleta River to the Point of Beginning.

- D. Full scale maps of the Illustrative Master Plan presented in Figure 1, as well as all the Regulating Plans and Street Development Parameters figures in this article, are on file with the Miami-Dade Department of Planning and Zoning.
- E. No provision in this article shall be applicable to any property lying outside the boundaries of the OUAD as described herein. No property lying within the boundaries of the OUAD shall be entitled to the uses or subject to the regulations provided in this article until an application for a district boundary change to OUAD has been heard and approved in accordance with the provisions of this chapter.

Figure 1: Illustrative Master Plan

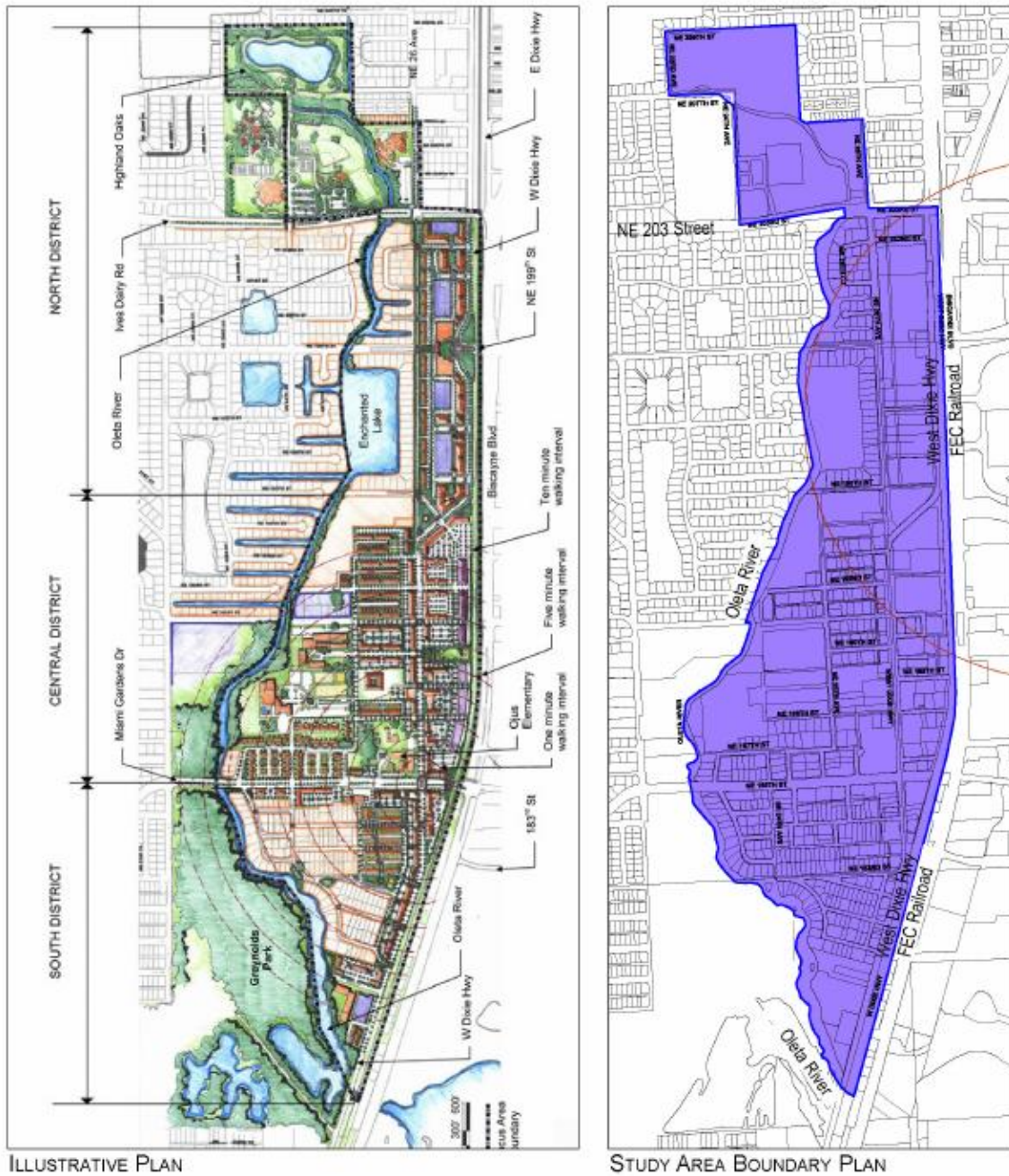

ILLUSTRATIVE PLAN

STUDY AREA BOUNDARY PLAN

KEY

-  Proposed Buildings
-  Existing Buildings
-  MUC Circle
-  Charrette Study Area Boundary
-  Ojus Urban Area District

Sec. 33-284.99.15 Ojus Urban Area District (OUAD) Requirements.

Except as provided herein, all developments within the OUAD shall comply with the requirements provided in Article XXXIII(K), Standard Urban Center District Regulations, of this code.

Sec. 33-284.99.17 Uses.

Except as provided herein, all permitted, conditionally permitted, and temporary uses within the OUAD shall comply with Section 33-284.83 of this Code.

1. As provided in the Land Use Regulating Plan, no duplexes shall be permitted in areas designated:
 - a. Residential (R) with a maximum permitted density of 6 dwelling units per net acre; and
 - b. Residential Modified (RM) with maximum permitted densities greater or equal to 36 units per net acre.
2. No municipal recreation building, playground, or park owned and operated by a municipality, county, state, or the federal government shall be permitted in areas designated R on the Land Use Regulating Plan.
3. No civic uses shall be permitted in areas designated R on the Land Use Regulating Plan, except for educational facilities on properties not to exceed 5 acres.
4. Industrial uses. Notwithstanding the provisions of Section 33-284.83 (A)(4), only the following uses shall be permitted in the Industrial District (ID) area. These uses shall be allowed in conformance with the Land Use Regulating Plan and the Street Type Development Parameters.
 - a. All uses permitted in the IU-1 zoning district
 - b. All uses permitted in the IU-2 zoning district after public hearing pursuant to section 33-311(A)(3) of this code.
 - c. MC uses at a maximum density of 52 units net acre or at a maximum density of 60 units per net acre with the purchase of the appropriate number of Severable Use Rights pursuant to Sections 33B-41 to 33B-47 of this code.
 - d. live-work units as provided in Sec. 33-284.83(A)(4)(b).

- e. On lots fronting West Dixie Highway and south of NE 195 Street, all uses permitted in the Mixed Use Main Street (MM), at a minimum density of 12 units per net acre and at a maximum density of 52 units net acre, or a maximum density of 60 units per net acre with the purchase of the appropriate number of Severable Use Rights as permitted by Section 33B-41 to Section 33B-47 of this code
 - f. On lots fronting NE 26th Avenue, all uses permitted in the Residential Modified (RM), at a minimum density of 12 units per net acre and a maximum density of 36 units net acre.
5. Institutional uses. The following additional uses shall be permitted in the Institutional (I) area in accordance with the Land Use Regulating Plan and the Street Types Development Parameters.
- a. Civic uses in accordance with the Street Types Development Parameters.
 - b. On lots located west of NE 25th Avenue, all uses permitted in the Residential (R), with a minimum density of 6 units per net acre and a maximum density of 13 units per net acre.
 - c. On lots located east of NE 25th Avenue, all uses permitted in the Residential Modified (RM), with a minimum density of 12 units per net acre and a maximum density of 36 units per net acre.
6. Conditionally Permitted Uses. Notwithstanding the provisions of Section 33-284.83 (B), only the following conditional uses shall be permitted subject to the administrative approval of a site plan, pursuant to Section 33-284.88 of this code.
- 1. Liquor package stores shall be permitted only in the Core Sub-district and only in compliance with all applicable regulations of this code.

Sec. 33-284.99.18 The Regulating Plans.

The Regulating Plans shall consist of the following controlling plans, as defined and graphically depicted in this section.

- A. The Street Types Plan, which establishes a hierarchy of street types in existing and future locations. The five Street Types and the hierarchy of streets (from

most important to least important in accommodating all types of activity) are U.S. 1, Main Street, Boulevard, Minor Street, and Service Road.

- B. The Sub-districts Plan, which delineates 3 Sub-districts: Core, Center and Edge. These Sub-districts shall regulate the allowable intensity of development in accordance with the Comprehensive Development Master Plan and this article.
- C. The Land Use Plan, which delineates the areas where specified land uses and development of various types and intensities shall be permitted.
- D. The Building Heights Plan, which establishes the minimum and maximum allowable number of stories.
- E. The Designated Open Space Plan, which designates open spaces. The designated open spaces shall be controlled by anchor points.
- F. The New Streets Plan, which shows the location and the number of new streets needed to create the prescribed network of streets within the Ojus Urban Area. All new A streets shall be required in the same general location as shown on the New Streets Plan. All B streets shall be located as provided in Section 33-284.86(F) of this code.
- G. The Bike Route Plan, which depicts the designated bike routes, including the bike facility requirements if any, which shall be shown in all development plans.

A. Street Types Plan

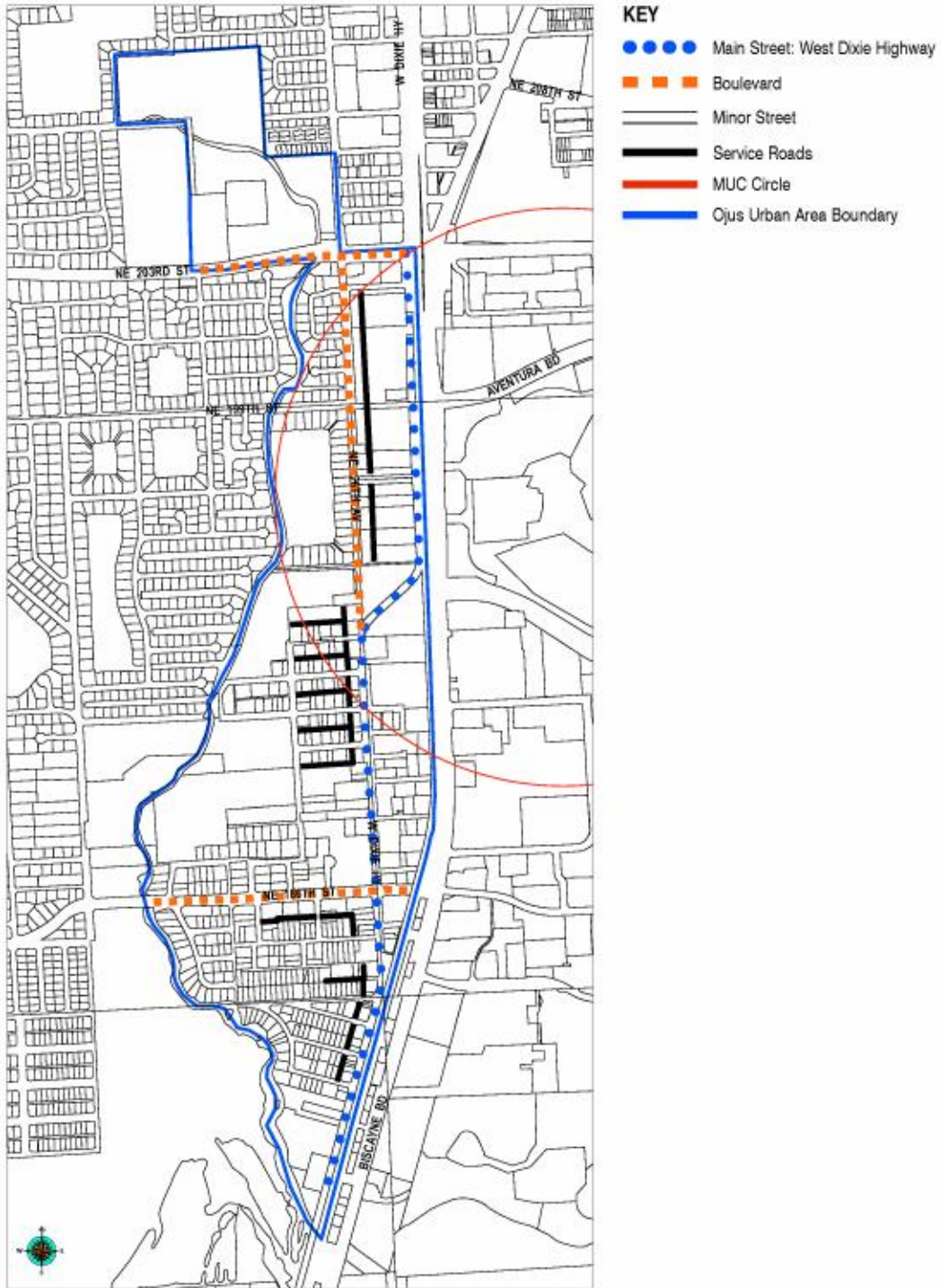

C. Land Use Plan

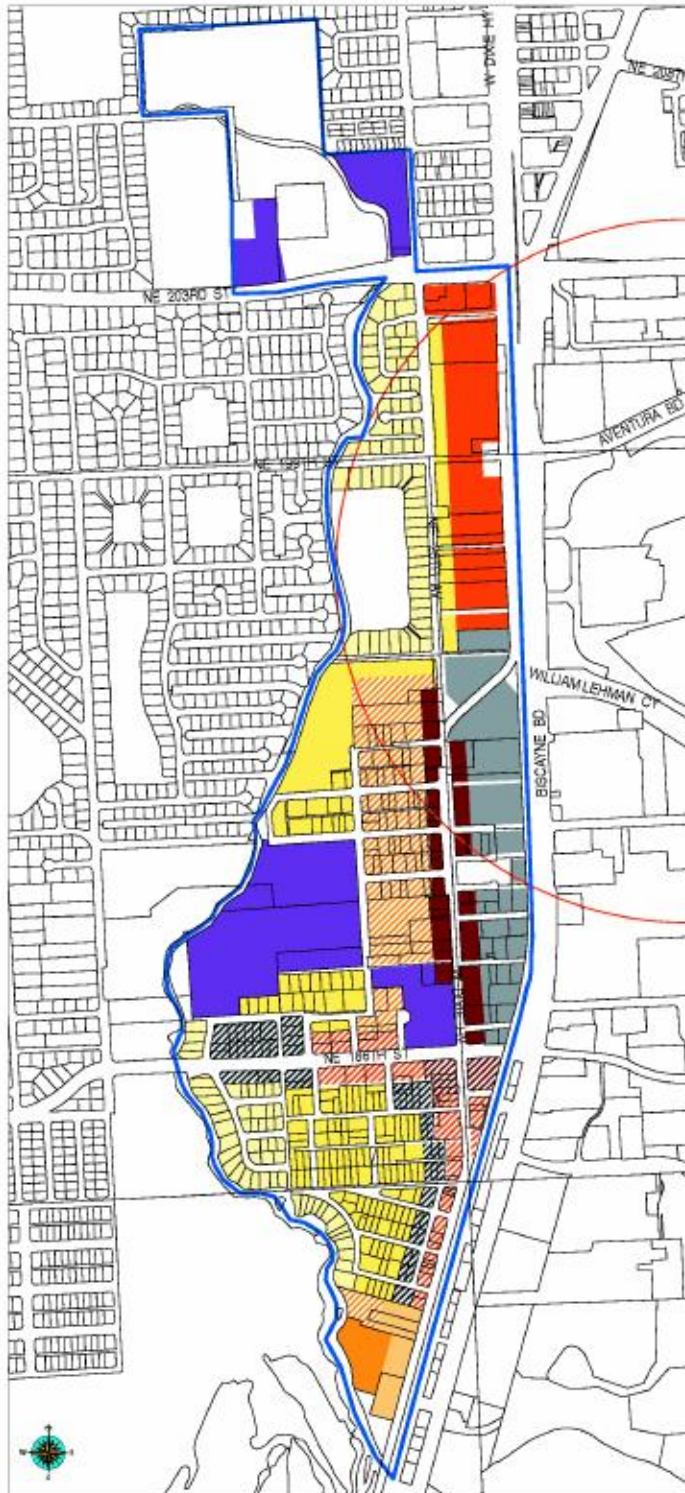

KEY

-  **MM:** Mixed-use Main Street: First and second floors - businesses, professional offices, civic, education and government offices; second floor and above - residential (Min. 12 units/acre net, Max. 52* units/acre net)
-  **MM:** Mixed-use Main Street: First and second floors - businesses, professional offices, civic, education and government offices; second floor and above - residential (Min. 12 units/acre net, Max. 36 units/acre net)
-  **MC:** Mixed-use Corridor: residential, businesses, professional offices, civic, education and government offices (Max. 52* units/acre net)
-  **MC:** Mixed-use Corridor: residential, businesses, professional offices, civic, education and government offices (Max. 82* units/acre net)
-  **MC:** Mixed-use Corridor: residential, businesses, professional offices, civic, education and government offices (Max. 36 units/acre net)
-  **RM:** Residential Modified: Rowhouse, urban villa, apartment dwellings (Min. 12 units/acre net, Max. 52* units/acre net)
-  **RM:** Residential Modified: Rowhouse, urban villa, apartment dwellings (Min. 12 units/acre net, Max. 36 units/acre net)
-  **RM:** Residential Modified: Duplex, urban villa, rowhouse, and live-work dwellings (Min. 8 units/acre net, Max. 18 units/acre net)
-  **R:** Residential: Single family detached dwellings (Max. 6 units/acre net)
-  **R:** Residential: Single family detached, duplex, urban villa, rowhouse dwellings (Min. 6 units/acre net, Max. 13 units/acre net)
-  **ID:** Industrial District: In all floors and all Sub-districts: IU-1 uses are permitted and IU-2 uses after public hearing. In addition:
 1. MC (Max. 52* units/acre net)
 2. Live-work units
 3. South of NE 195 St: MM along West Dixie Highway only (Min. 12 units/acre net, Max. 52* units/acre net)
 4. RM along NE 26th Avenue only (Min. 12 units/acre net, Max. 36 units/acre net)
-  **I:** Institutional: Civic, education and government offices and residential as per Sec 33-264.99.16(A)(5) of this Code.
- MUC Circle
- Ojus Urban Area Boundary

See Sections 33-264.83 and 33-264.99.16 of this code for specific permitted uses in each land use area.

*Residential density may be increased through the use of Severable Use Rights (SURs). See Sec. 33B-45(g)(15) of this code for applicability.

E. Designated Open Space Plan

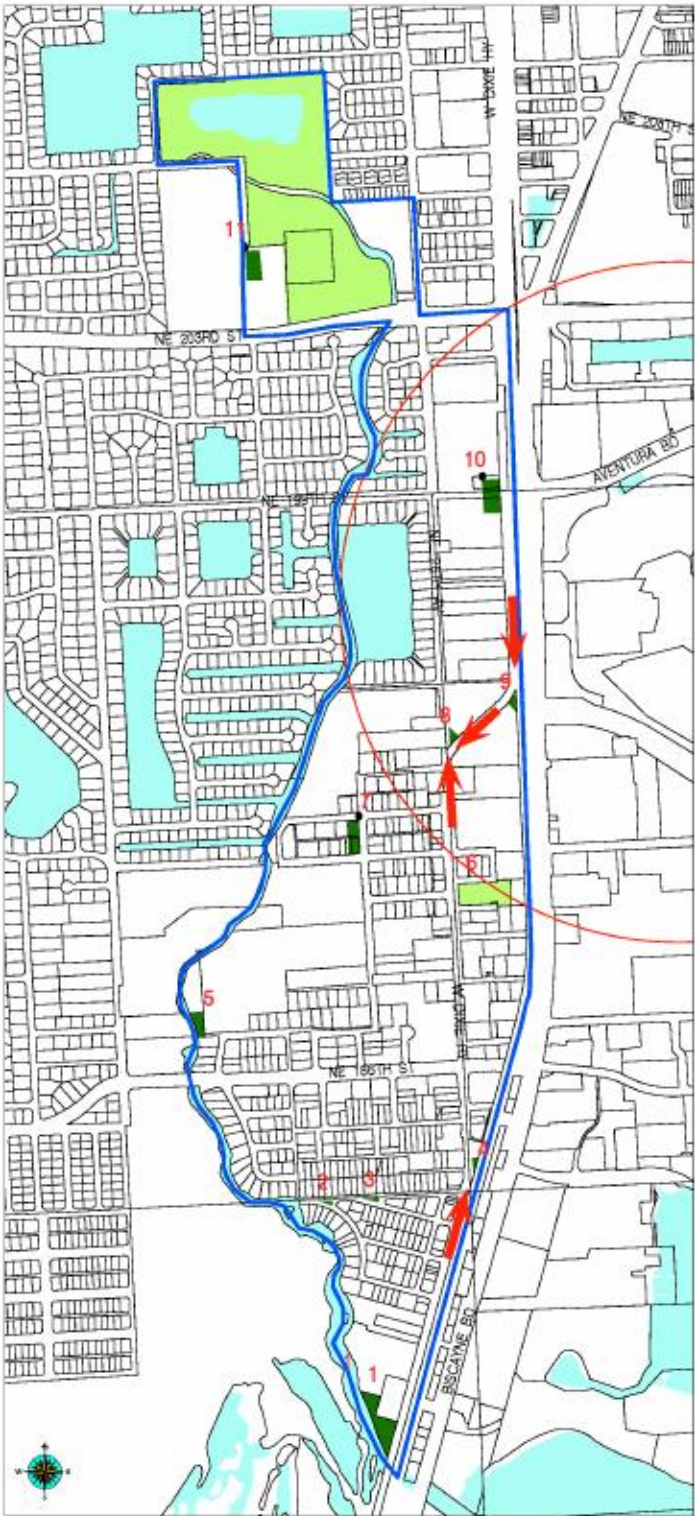

- KEY**
- Designated Open Space: G: Green; S: Square; P: Plaza
 - Existing Park
 - Existing Water Bodies
 - Street Vista
 - Anchor Point
 - MUC Circle
 - Ojus Urban Area Boundary

Number	Type	Area
1.	G	48,600 sq. ft.
2.	G	N/A
3.	G	N/A
4.	P	2,500 sq. ft.
5.	G	14,500 sq. ft.
6.	S	Existing Park
7.	G	23,500 sq. ft.
8.	G	5,500 sq. ft.
9.	G	4,000 sq. ft.
10.	G	35,500 sq. ft.
11.	G	26,000 sq. ft.

The open space shall provide the general square footage shown in this Designated Open Space Plan.

F. New Streets Plan

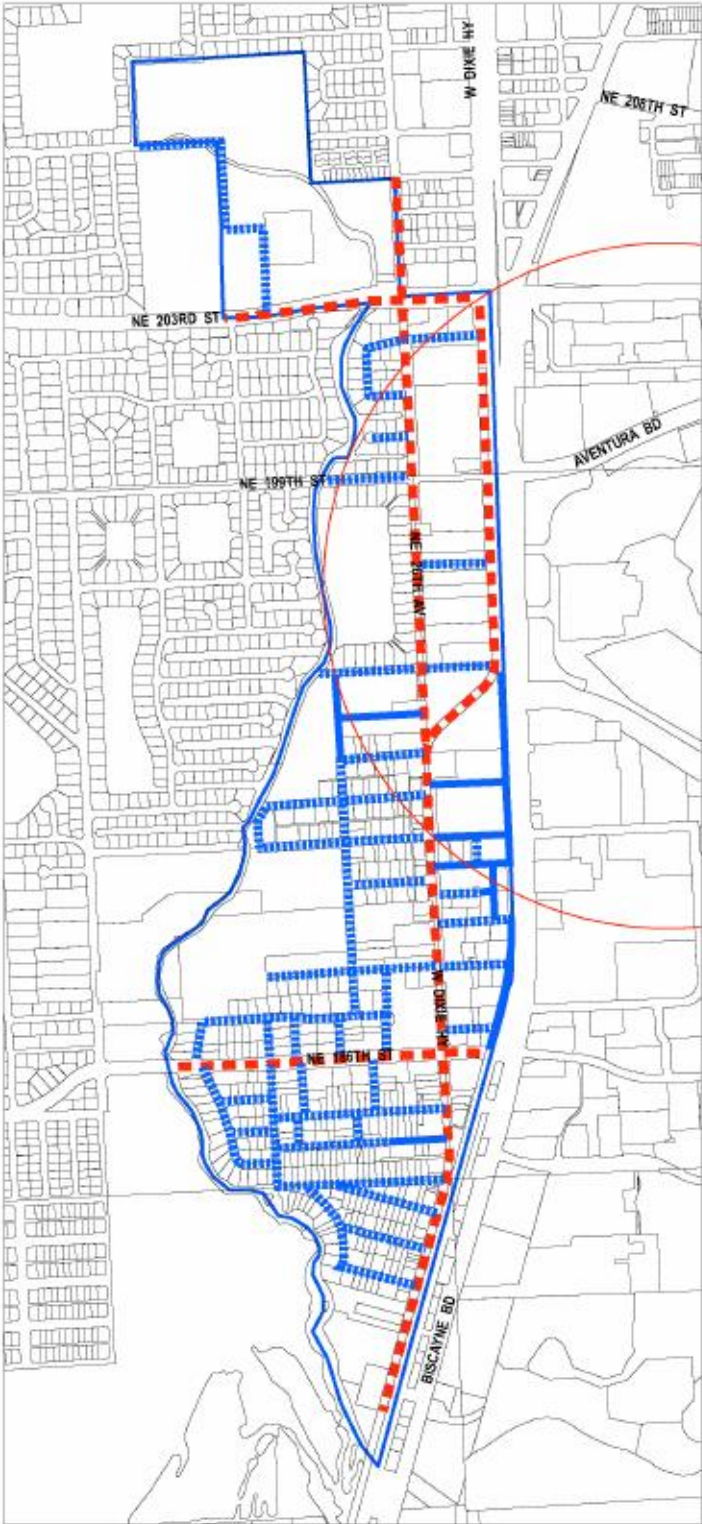

KEY

- Existing 'A' Street
- New 'A' Street
- Existing 'B' Street
- New 'B' Street
- MUC Circle
- Ojus Urban Area Boundary
- Property Ownership Pattern

Note: New street allocations are based on the Illustrative Plan and are approximate.

Sec. 33-284.99.19 Building Placement and Street Type Development Parameters

- A. All new development and redevelopment within the OUAD shall comply with the Building Placement and Design Parameters as provided in Section 33-284.85 of this code.
- B. All new development and redevelopment within the OUAD shall comply with the Street Type Parameters as provided herein:

Street type	Minimum Required Configuration
Main Street	As provided herein
Boulevard (NE 26 th Avenue)	As provided herein
Boulevard	As provided in section 33-284.85
Minor Street	As provided herein or in section 33-284.85
Service Road	As provided in section 33-284.85
Pedestrian Passage	As provided in section 33-284.85

- C. Unless otherwise provided by the Building Placement and Design Parameters in section 33-284.85 of this code, the following street setbacks shall be required for mixed-use/industrial buildings located in areas designated as MM, MC and ID within the OUAD:

Street Type	Required Setback		
	Core	Center	Edge
Main Street	0' * or 12'	N/A	N/A
Boulevard (NE 26 Avenue)	N/A	0' or 10'	10' or 15'
Boulevard (Other)	0'	0' or 10'	10' or 15'
Minor Street	0' or 10'	0' or 10'	10' Or 15'
Note: * 12' colonnade required when setback is 0' ** as provided in Section 33-284.99.19 of this code N/A not applicable			

BOULEVARD (NE 26TH AVENUE)

CORE/CENTER

STREET SECTION

Key:

- s: sidewalk
- g: green
- c: curb and gutter
- ln: lane
- medi: median
- p: parking
- bl: bike lane
- col: colonnade
- setb: Setback
- PL: property line
- Min: Minimum
- Max: Maximum
- Req: Required
- Ded: Dedication

--- Property Line

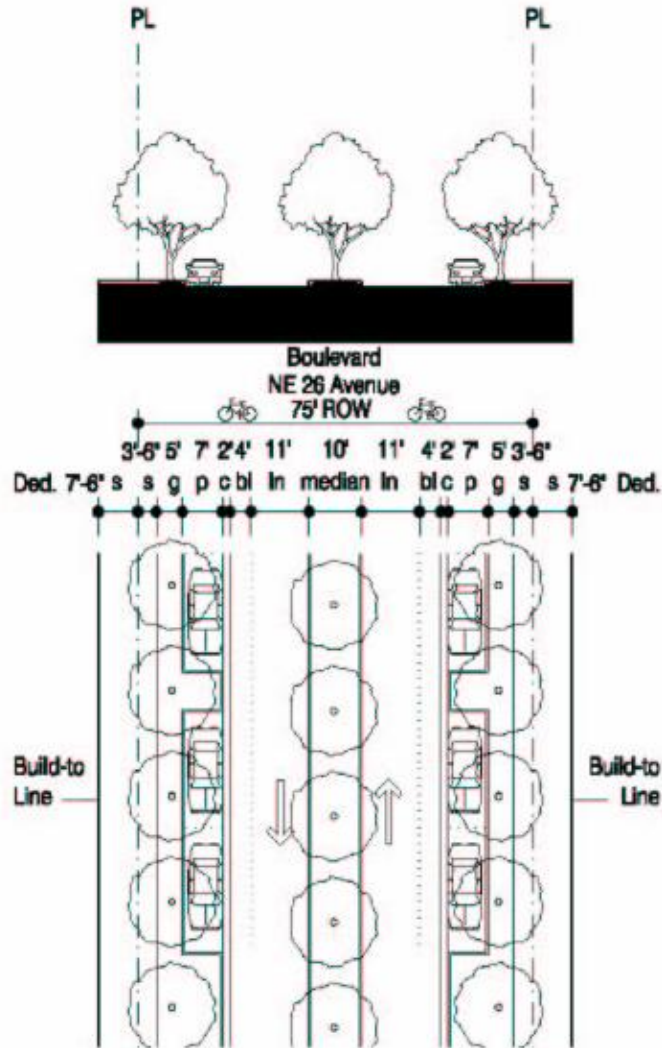

**LANDSCAPE/
OPEN SPACE**

Parking lot buffers and street trees shall meet all requirements of this article and Chapter 18-A of this code, except street trees shall have a minimum diameter breast height of 4". Street trees shall be planted in a 5' continuous landscape strip. Permanent irrigation is required.

PARKING

On-street parking shall count towards the minimum required parking.

OTHER ELEMENTS

The front setback shall be hard surfaced and finished to match the adjoining sidewalk. A minimum of 5' clear width within the setback shall be kept unobstructed for pedestrians. Weather protection elements shall be provided on the building facade. Perimeter walls, fences, hedges, entrances and pedestrian pass throughs shall be provided as specified in the General Requirements. On all Boulevard intersections, the median shall have a mountable curb.

BOULEVARD (NE 26TH AVENUE)

EDGE

STREET SECTION

Key:

- s: sidewalk
- g: green
- c: curb and gutter
- ln: lane
- med: median
- p: parking
- bl: bike lane
- col: colonnade
- setb.: Setback
- PL: property line
- Min: Minimum
- Max: Maximum
- Req: Required
- Ded: Dedication

--- Property Line

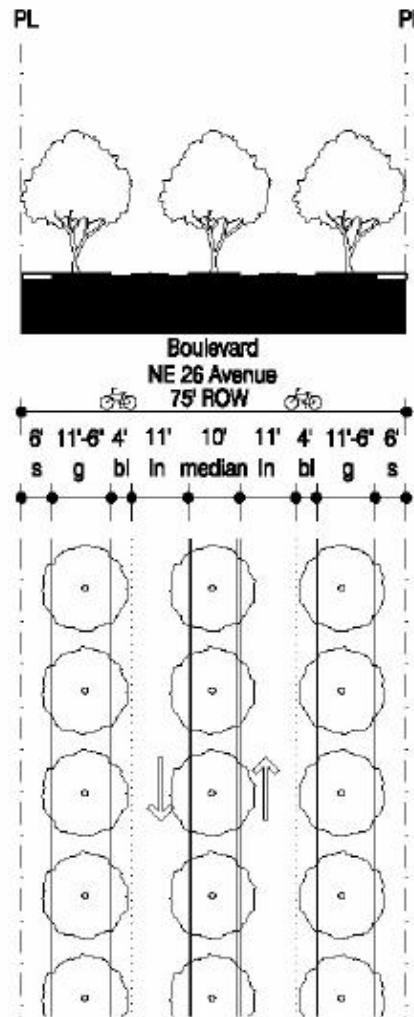

**LANDSCAPE/
OPEN SPACE**

Parking lot buffers and street trees shall meet all requirements of this article and Chapter 18-A of this code, except street trees shall have a minimum diameter breast height of 4". Street trees shall be planted in a 11'-6" continuous landscape strip.

PARKING

N/A

OTHER ELEMENTS

The front setback shall be landscaped.
Perimeter walls, fences, hedges, entrances and pedestrian pass throughs shall be provided as specified in the General Requirements.
On all Boulevard intersections, the median shall have a mountable curb.

MINOR STREET (No Sidewalk)

EDGE

STREET SECTION

- Key:**
 s: sidewalk
 g: green
 c: curb and gutter
 ln: lane
 med: median
 p: parking
 bl: bike lane
 col: colonnade
 setb.: Setback
 PL: property line
 Min: Minimum
 Max: Maximum
 Req: Required
 Ded: Dedication
- Property Line

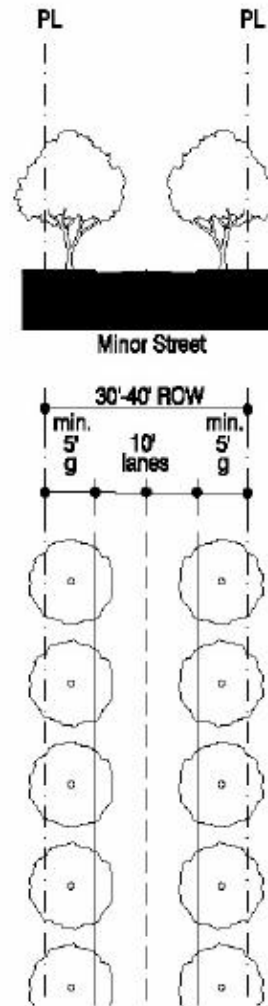

**LANDSCAPE/
OPEN SPACE**

Parking lot buffers and street trees shall meet all requirements of this article and Chapter 13-A of this code, except street trees shall have a minimum diameter breast height of 4". Street trees shall be planted in a 5' minimum continuous landscape strip.

PARKING

N/A

OTHER ELEMENTS

The front setback shall be landscaped.
 Perimeter walls, fences, hedges, entrances and pedestrian pass throughs shall be provided as specified in the General Requirements.

Sec. 33-284.99.20 General Requirements.

In addition to the requirements in Section 33-284.86 of this code, and to retain the character of the development within the OUAD, all new development and redevelopment shall comply with the following:

A. Heights of Buildings.

1. Except where exempted as depicted on the Building Heights Plan, where a proposed development abuts an area designated Residential (R) on the Land Use Regulating Plan, the height of the proposed development along the abutting property line, for a minimum depth of 50 feet, shall be no greater than the maximum height allowed in the abutting area designated R. Examples of the required height transition are shown herein.



Example of building heights transition from mixed-use to single-family

Each story shall have a maximum height of 16 feet, as measured from floor to floor. Any height above 16 feet shall count as an additional story, except that a single story may have a maximum height of 30 feet, provided that no mezzanine area intended for commercial use exceeds 10 percent and no mezzanine area intended for residential use exceeds 80 percent of the floor area of that story.

B. Architectural Guidelines.

To retain the character of the development in the OUAD area and to recognize its architectural history, all new single-family development within the OUAD area shall conform with either the Florida Vernacular or the Mission style as shown in the figures below. Specifically and at a minimum, all new single-family homes within the area shall include each of the required elements, respective to the chosen architectural style, described herein:

Architectural Style	Required elements
Florida Vernacular	<ol style="list-style-type: none"> 1. Side gabled roof with shingles and a slope of 6:12 or 12:12 2. Operable, boarded shutters sized to the window opening 3. Attached front porch
Mission	<ol style="list-style-type: none"> 1. Shaped Mission dormer or roof parapet 2. Arched openings 3. Overhanging eaves with exposed rafters.

Additional defining elements are shown in the figures provided herein, and shall be optional.

FLORIDA VERNACULAR

DEFINING ELEMENTS



PORCH TYPES

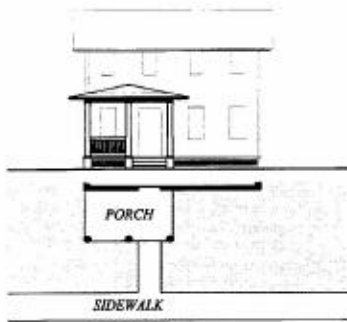

SMALL PORCH
1 or 2 story front porch that covers a minimum of 50% of the front facade and encroaches the allowable depth into the building's front setback.

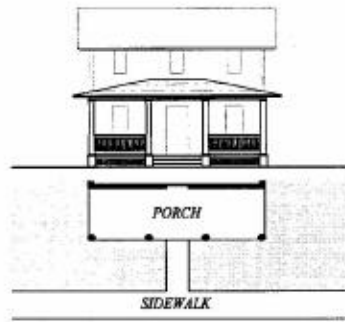

LARGE PORCH
1 or 2 story front porch that covers a minimum of 80% of the front facade and encroaches the allowable depth into the building's front setback.

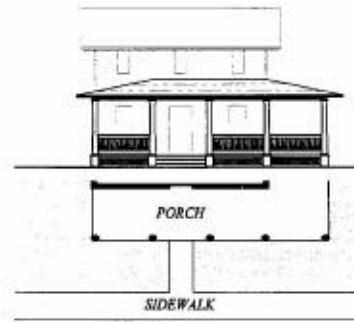

CORNER LOT PORCH
1 or 2 story front porch that covers a minimum of 50% of the front facade and extends at least two column bays along the side street facade (at corner lots only). This porch also encroaches the allowable depth into the building's front and side setback.

WINDOWS

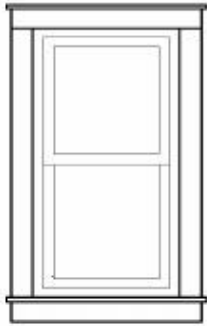

DOUBLE-HUNG
Single light per sash

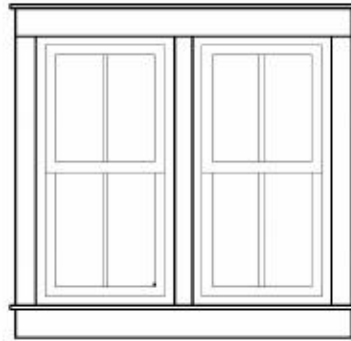

GROUPED DOUBLE-HUNG
With divided sash

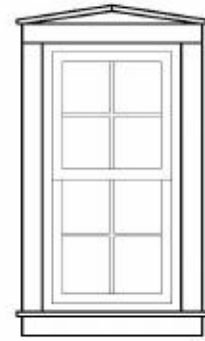

'4 over 4' DOUBLE-HUNG
With pedimented frame

DOORS

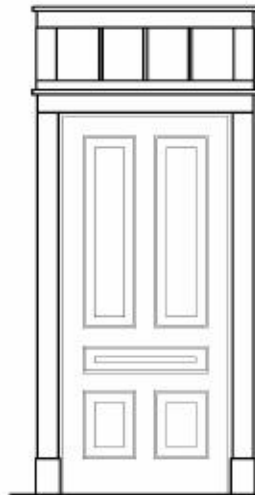

SOLID 5-PANELED
With fixed transom lights

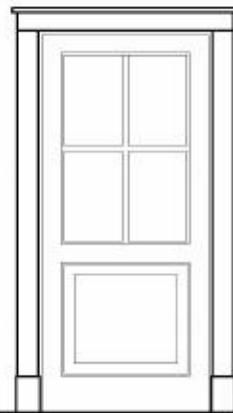

SOLID 1-PANEL
With fixed glass and 4 lights

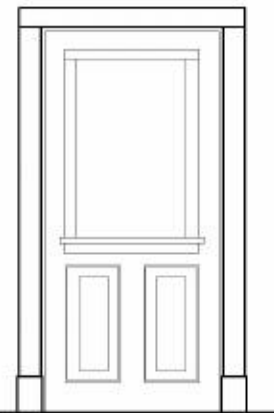

SIMPLIFIED FRAME
With fixed undivided glazing

RAILINGS AND BALUSTRADES

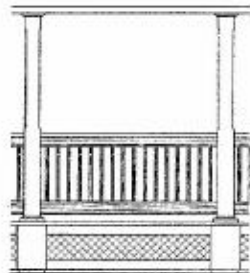

STRAIGHT SQUARE SPINDLES

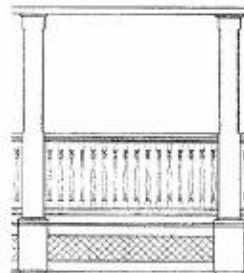

TURNUED SPINDLES

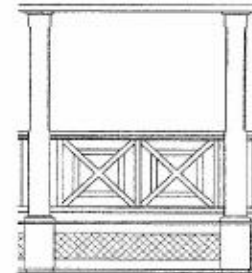

DECORATIVE WOODEN BALUSTRADE

COLUMNS, POSTS, AND PIERS

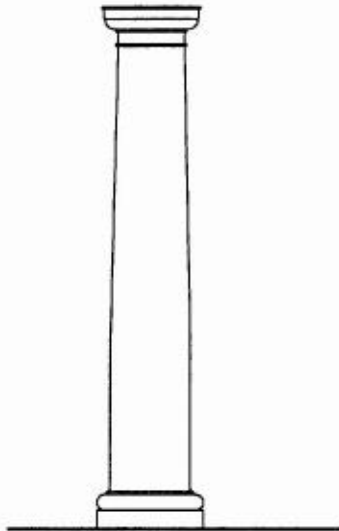

ROUNDED
SMOOTH
TUSCAN COLUMN

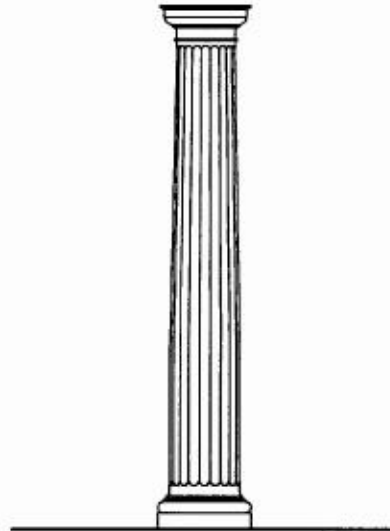

ROUNDED
FLUTTED
DORIC COLUMN

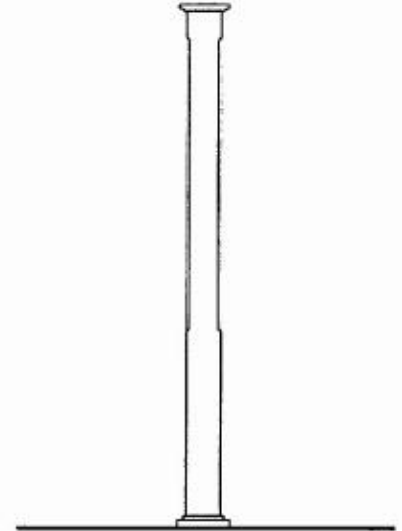

SQUARE WOODEN POST
WITH CHAMFER

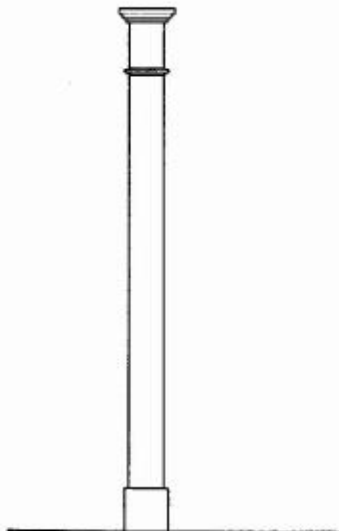

SQUARE WOODEN POST
WITH COLLAR

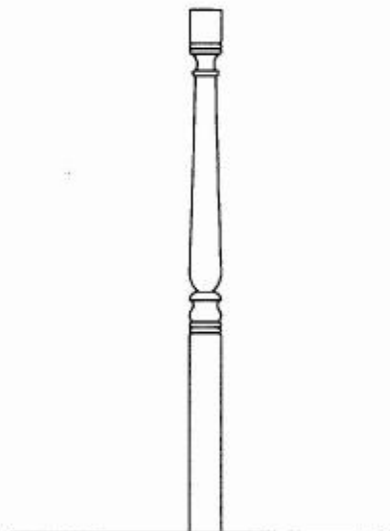

TURNED WOODEN POST

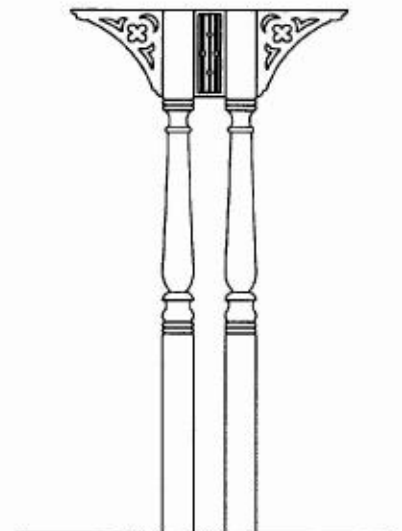

COUPLED TURNED
WOODEN POSTS WITH
ORNAMENTAL BRACKETS

MISSION STYLE

DEFINING ELEMENTS

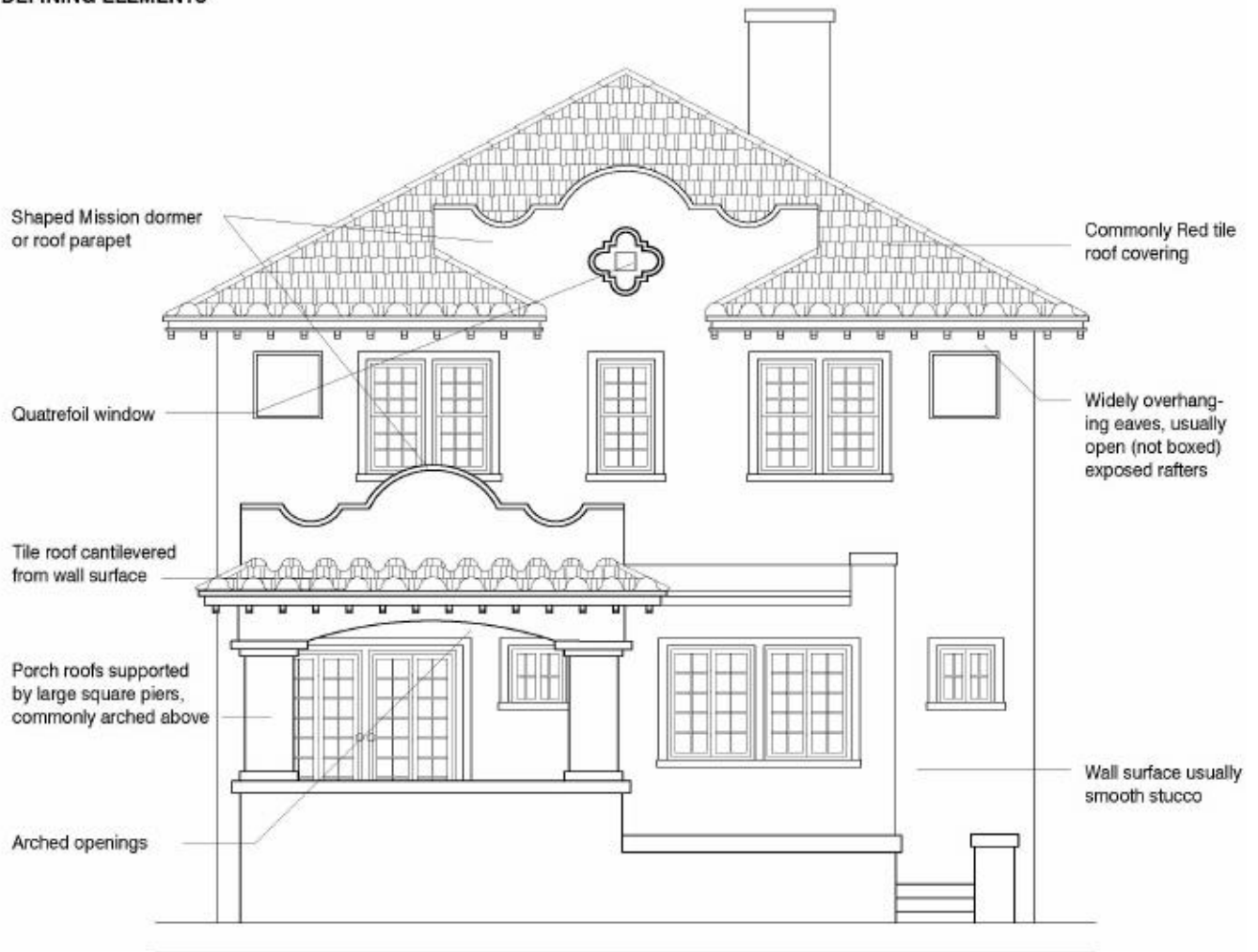

PRINCIPLE SUBTYPES

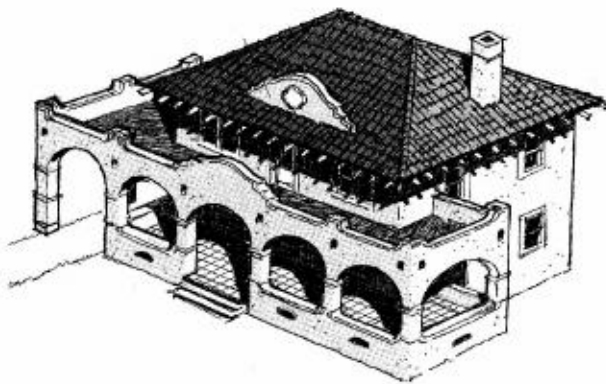

SYMMETRICAL

Balanced symmetrical facades. These are most commonly of simple square or rectangular plan with hipped roofs.

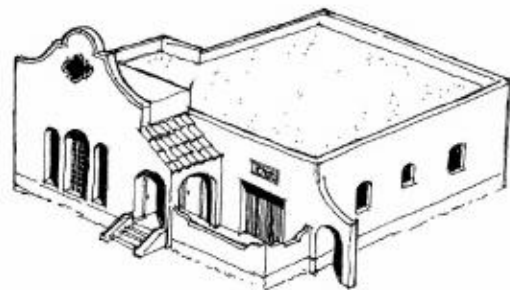

ASYMMETRICAL

Usually the facade asymmetry is superimposed on a simple square or rectangular plan.

WINDOWS

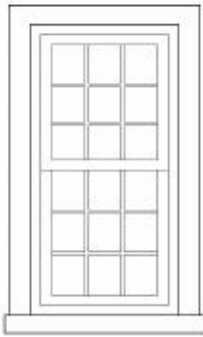

DOUBLE-HUNG
With divided sash

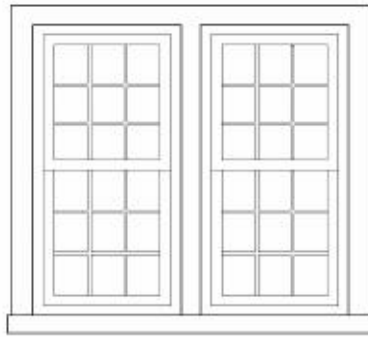

GROUPED DOUBLE-HUNG
With divided sash

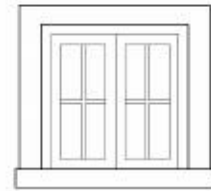

SQUARE FIXED



QUATREFOIL

TYPICAL DORMERS AND PARAPETS

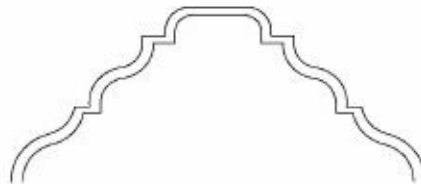
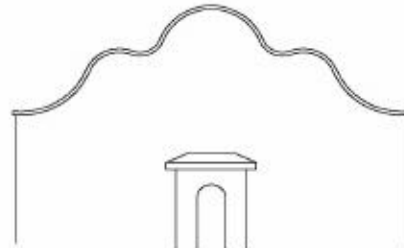
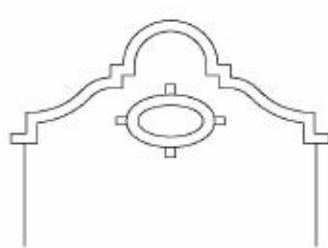

Sec. 33-284.99.21 Conflicts with other Chapters and Regulations.

This article shall govern in the event of conflicts with other zoning, subdivision, or landscape regulations of this code, or with the Miami-Dade Department of Public Works Manual of Public Works.

Section 33-284.99.22 Non-conforming Structures, Uses, and Occupancies.

Nothing contained in this article shall be deemed or construed to prohibit a continuation of a legal nonconforming structure, use, or occupancy in the OUAD that either (1) was existing as of the date of the district boundary change on the property to OUAD or (2) on or before said date, had received final site plan approval through a public hearing pursuant to this chapter or through administrative site plan review or had a valid building permit. However, any structure, use, or occupancy in the OUAD that is discontinued for a period of at least six months, or is superseded by a lawful structure, use or occupancy permitted under this chapter, or that incurs damage to the roof or structure to an extent of 50 percent or more of its market value, shall be subject to Section 33-35(c) of this code. However, a lawfully existing single-family home use that is discontinued for a period of at least six months or that incurs damage to the roof or structure to an extent of 50 percent or more of its market value, shall not be subject to Section 33-35(c) of this code.

(Ord. No. 06-86, June 6, 2006; Ord. No. 07-94, July 10, 2007)